



深圳市海尔希科技发展有限公司

Shenzhen Haierxi Technology Development Limited

HEX系列产品—HEX102A

HEX-102A

Halogen Free

HALL ELEMENT



1.Application

This specification sheet is applied to Hall sensor that HEX.TEC supplies.

2. Electrical Characteristics

2.1 Maximum Ratings

(Ta : 25°C)

Parameter	Symbol	Rating	Unit
Maximum Input Current	I _{max}	20 (at 25°C)	mA
Maximum Power Dissipation	P _{max}	150 (at 25°C)	mW
Operating Temperature Range	T _{op}	-40 ~ +120	°C
Storage Temperature Range	T _{st}	-40 ~ +150	°C

2.2 Electrical Characteristics (Measured at 25°C)

Parameter	Symbol	Measurement Conditions	Min	Max	Unit
Output Hall Voltage	V _H	V _{in} =1V, B=500G	196	320	mV
Input Resistance	R _{in}	I=0.1mA	240	550	Ω
Output Resistance	R _{out}	I=0.1mA	240	550	Ω
Offset Voltage	V _O	V _{in} =1V, B=0G	-7	+7	mV
Temp. Coeff. of V _H	α	Ta=0 ~ +40°C	—	-1.8	% /°C
Temp. Coeff. of R _{in} , R _{out}	β	Ta=0 ~ +40°C	—	-1.8	% /°C

※ V_H=V_{HM}-V_O (V_{HM} : The output voltage measured at 500G.)

2.3 Rank Classification and Mark on Output Hall Voltage

Output Hall Voltage, V _H (mV)	Rank	Mark	Measurement Conditions
196 ~ 236	D	•SD	V _{in} =1V, B=500G (Constant Voltage)
228 ~ 274	E	•SE	
266 ~ 320	F	•SF	



3. Method for Mounting

3.1 Lead Frame

- 1) The material of lead frame is phosphor bronze alloy and the die bonded surface is plated by silver. The minimum thickness of plating is 3.0 μ m.
- 2) Lead Frame is plated by pure Sn and the thickness is controlled by 4~12 μ m.

3.2 Soldering Conditions on PCB

- 1) No rapid heating and cooling is desired.
- 2) Preheating is recommended for 1~2minutes at 150~190 $^{\circ}$ C.
- 3) Reflowing is recommended for 10~20seconds at 220~260 $^{\circ}$ C.

3.3 Soldering Method and Temperature

Items	Methods	Temperature
Reflow	Soldering by passing the heated zone	Max 260 $^{\circ}$ C in 10sec
Solder Iron	Soldering by solder-iron	Max 350 $^{\circ}$ C in 3sec

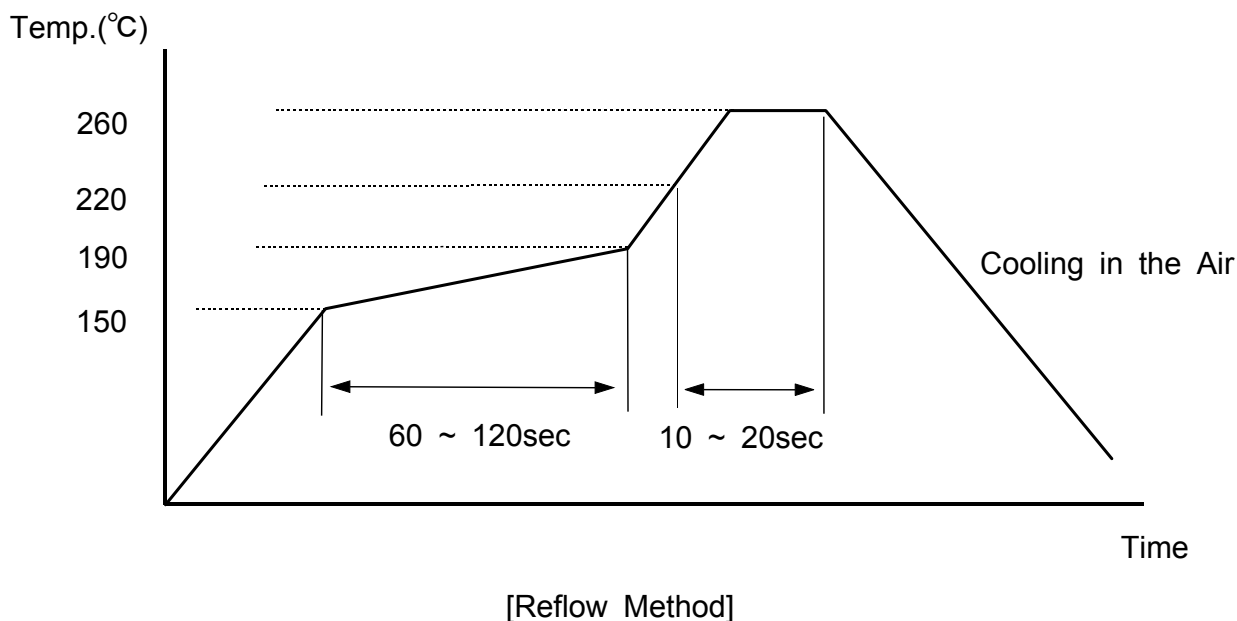



4. Packaging

4.1 Taping

- 1) HEX-102A should be packed marking side to cover tape side and put long side to tape running direction. 180° rotation has no effect on the application.
- 2) At least, 40mm vacant parts are made both front and rear side of tape.

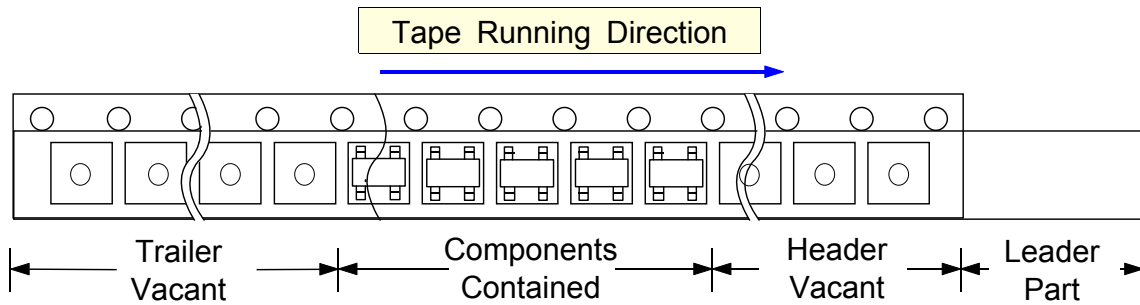

4.2 Handling Methods of Tape

- 1) Pull Strength(F) = 20~70g

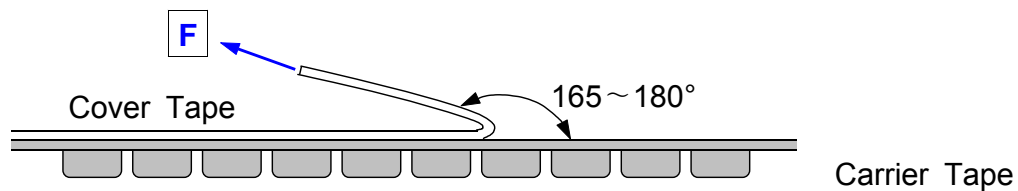

- 2) Devices should not run out of a pocket when tape is bent down 15mm curvature.
- 3) Devices should not stick to cover tape.
- 4) Devices should be kept below 40°C and below RH80% in the shade.
- 5) Tape has no joint.

4.3 Packing Unit

- 1) 1,800pcs of devices are packed in one reel.
- 2) Five reels are packed in one inner box.
- 3) Four inner boxes, 36,000pcs of devices, are packed in one outer box.
- 4) Dummy could be packed for safe dealing.



5. External Dimensions and Appearance

5.1 External Dimensions (Unit:mm)

Four leads of input-output terminals are designed in the diagonally symmetric mode and are equal in dimensions. HEX-102A could be used without considering on the rotation of 180°.

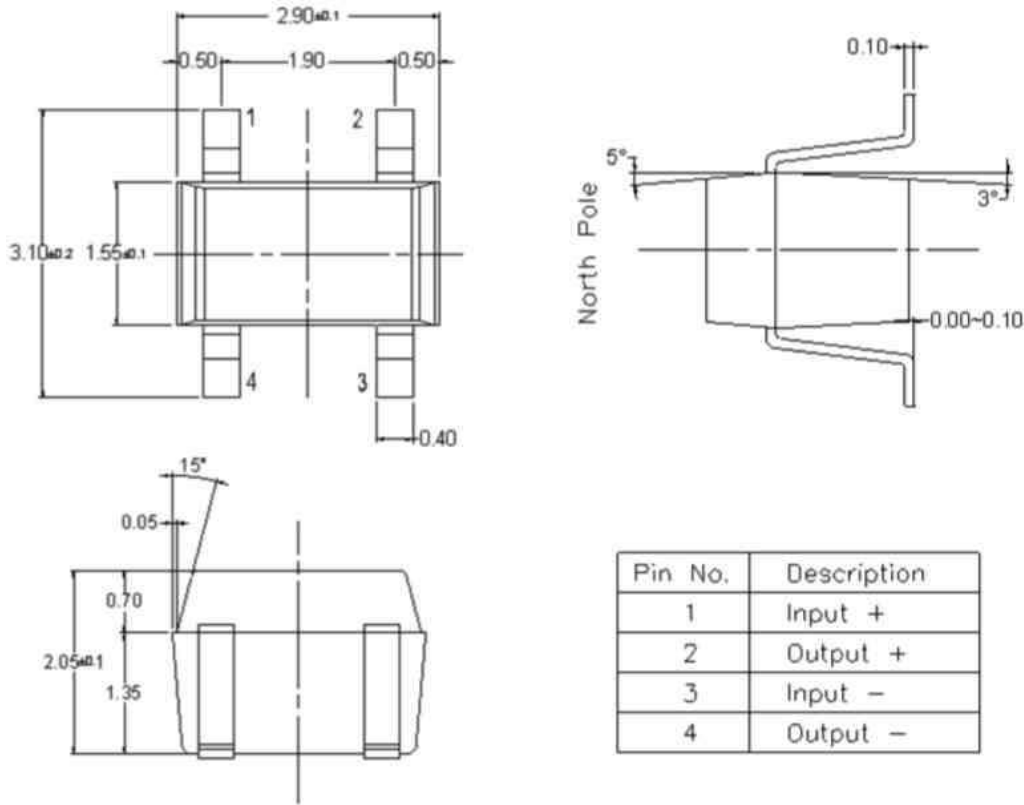

[Package Dimensions]

5.2 Marking Method

Devices should be marked by LASER beam in the form of 「Rank」.

